

Roll No.

--	--	--	--	--	--	--

Series SHC

Code No. 91

- Please check that this question paper contains 11 printed pages.
- Code number given on the right hand side of the question paper should be written on the title page of the answer-book by the candidate.
- Please check that this question paper contains 7 questions.
- Please write down the serial number of the question before attempting it.

COMPUTER SCIENCE

Time allowed : 3 hours

Maximum Marks: 70

Instructions:

- (i) *All questions are compulsory.*
- (ii) *Programming Language : C++*

1. (a) Differentiate between a Logical Error and Syntax Error. Also give suitable examples of each in C++. 2

(b) Name the header file(s) that shall be needed for successful compilation of the following C++ code : 1

```
void main( )
{
    char Text[40];
    strcpy(Text, "AISSCE");
    puts(Text);
}
```

(c) Rewrite the following program after removing the syntactical error(s), if any. Underline each correction. 2

```
#include <iostream.h>
const int Size 5;
void main()
{
    int Array[Size];
    Array = {50,40,30,20,10};
    for(Ctr=0; Ctr<Size; Ctr++)
        cout>>Array[Ctr];
}
```

(d) Find the output of the following program :

2

```
#include<iostream.h>
void main()
{
    int Numbers[] = {2,4,8,10};
    int *ptr = Numbers;
    for (int C = 0; C<3; C++)
    {
        cout<< *ptr << "@";
        ptr++;
    }
    cout<<endl;
    for(C = 0; C<4; C++)
    {
        (*ptr)*=2;
        --ptr;
    }
    for(C = 0; C<4; C++)
        cout<< Numbers [C]<< "#";
    cout<<endl;
}
```

(e) Find the output of the following program :

3

```
#include<iostream.h>
void Indirect(int Temp=20)
{
    for (int I=10; I<=Temp; I+=5)
        cout<<I<<" ";
    cout<<endl;
}
void Direct (int &Num)
{
    Num+=10;
    Indirect(Num);
}
void main()
{
    int Number=20;
    Direct(Number);
    Indirect();
    cout<< " Number=" <<Number<<endl ;
}
```

- (f) In the following C++ program what is the expected value of Myscore from Options (i) to (iv) given below. Justify your answer. 2

```
#include<stdlib.h>
#include<iostream.h>
void main( )
{
    randomize();
    int Score[] = {25,20,34,56, 72, 63}, Myscore;
    Myscore = Score[2 + random(2)];
    cout<<Myscore<<endl; }
```

- (i) 25
(ii) 34
(iii) 20
(iv) None of the above

2. (a) Differentiate between Protected and Private members of a class in context of Inheritance using C++. 2

- (b) Answer the questions (i) and (ii) after going through the following class: 2

```
class Science
{
    char    Topic[20];
    int    Weightage;
public:
    Science ( )                //Function 1
    {
        strcpy (Topic, "Optics" );
        Weightage = 30;
        cout<<"Topic Activated";
    }
    ~Science( )                //Function 2
    {
        cout'<<"Topic Deactivated";
    }
};
```

- (i) Name the specific features of class shown by Function 1 and Function 2 in the above example.
- (ii) How would Function 1 and Function 2 get executed ?

(c) Define a class Travel in C++ with the description given below :

4

Private Members :

T_Code of type string
No_of_Adults of type integer
No_of_Children of type integer
Distance of type integer
TotalFare of type float

Public Members :

- A constructor to assign initial values as follows :
T_Code with the word "NULL"
No_of_Adults as 0
No_of_Children as 0
Distance as 0
TotalFare as 0
- A function AssignFare() which calculates and assigns the value of the data member TotalFare as follows :

For **each** Adult

Fare (Rs)	For Distance (Km)
500	>=1000
300	<1000 & >=500
200	<500

For **each** Child the above Fare will be 50% of the Fare mentioned in the above table.

For example :

If Distance is 750, No_of_Adults = 3 and No_of_Children = 2

Then TotalFare should be calculated as

$$\text{No_of_Adults} * 300 + \text{No_of_Children} * 150$$

i.e. $3 * 300 + 2 * 150 = 1200$

- A function EnterTravel() to input the values of the data members T_Code, No_of_Adults, No_of_Children and Distance; and invoke the AssignFare() function.
- A function ShowTravel() which displays the content of all the data members for a Travel.

(d) Answer the questions (i) to (iv) based on the following code :

4

```
class Teacher
{
    char TNo[5], TName[20], Deptfl0];
    int Workload;
protected:
    float Salary;
    void AssignSal(float);
```

```

public:
    Teacher( ) ;
    void TEntry( ) ;
    void TDisplay( ) ;
};
class Student
{
    char Admno[10], SName[20], Stream[10];
protected:
    int Attendance, TotMarks;
public:
    Student( ) ;
    void SEntry( ) ;
    void SDisplay( ) ;
};
class School : public Student, public Teacher
};
    char SCode[10], SchName[20];
public:
    School ( ) ;
    void SchEntry( ) ;
    void SchDisplay( ) ;
};

```

- (i) Which type of Inheritance is depicted by the above example ?
- (ii) Identify the member function(s) that cannot be called directly from the objects of class School from the following :

TEntry()
SDisplay()
SchEntry()

- (iii) Write name of all the member(s) accessible from member functions of class School.
- (iv) If class School was derived privately from class Teacher and privately from class Student, then, name the member function(s) that could be accessed through Objects of class School.

3. (a) Write a function in C++ which accepts an integer array and its size as arguments and replaces elements having even values with its half and elements having odd values with twice its value.

4

Example : if an array of five elements initially contains the elements as

3, 4, 5, 16, 9

then the function should rearrange the content of the array as

6, 2, 10, 8, 18

- (b) An array Arr[15][20] is stored in the memory along the row with each element occupying 4 bytes. Find out the Base Address and address of the element Arr[3][2], if the element Arr[5][2] is stored at the address 1500.

4

- (c) Write a function in C++ to delete a node containing customer's information, from a dynamically allocated Queue of Customers implemented with the help of the following structure:

4

```
struct Customer
{
    int CNo;
    char CName[20];
    Customer *Link;
};
```

- (d) Write a function in C++ which accepts a 2D array of integers and its size as arguments and displays the elements of middle row and the elements of middle column.

2

[Assuming the 2D Array to be a square matrix with odd dimension
i.e. 3×3, 5×5, 7×7 etc...]

Example, if the array content is

```
3 5 4
7 6 9
2 1 8
```

Output through the function should be :

Middle Row : 7 6 9

Middle Column : 5 6 1

- (e) Evaluate the following postfix notation of expression :

2

```
15 3 2 + / 7 + 2 *
```

4. (a) Observe the program segment given below carefully, and answer the question that follows:

1

```
class Labrecord
{
    int Expno;
    char Experiment[20];
    char Checked;
    int Marks;
public :
    //function to enter Experiment details
    void EnterExp( );
    //function to display Experiment details
    void ShowExp ( ) ;
    //function to return Expno
    char RChecked ( ) {return Checked;}
    //function to assign Marks
    void Assignmarks(int M)
    {
        Marks = M;
    }
```

```

};
void MpdifyMarks()
{
    fstream File;
    File.open("Marks.Dat",ios::binary|ios::in|ios::out);
    Labrecord L;
    int Rec = 0;
    while (File.read((char*)&L, sizeof(L)))
    {
        if(L.RChecked( )== 'N' )
            L.Assignmarks(0)
        else
            L.Assignmarks(10)
            _____ //statement 1
            _____ //statement 2
        Rec ++ ;
    }
    File.close ();
}

```

If the function ModifyMarks() is supposed to modify Marks for the records in the file MARKS.DAT based on their status of the member Checked (containing value either 'Y' or 'N'). Write C++ statements for the **statement 1** and **statement 2**, where, **statement 1** is required to position the file write pointer to an appropriate place in the file and **statement 2** is to perform the write operation with the modified record.

- (b) Write a function in C++ to print the count of the word **the** as an independent word in a text file STORY.TXT. 2

For example, if the content of the file STORY.TXT is

There was a monkey in the zoo. The
monkey was very naughty.

Then the output of the program should be 2.

- (c) Given a binary file SPORTS.DAT, containing records of the following structure type :

```

struct Sports
{
    char    Event[20];
    char    Participant[10][30];
};

```

Write a function in C++ that would read contents from the file SPORTS.DAT and creates a file named ATHLETIC.DAT copying only those records from SPORTS.DAT where the event name is "Athletics". 3

5. (a) What is the importance of a Primary Key in a table ? Explain with a suitable example. 2

- (b) Consider the following tables Consignor and Consignee. Write SQL commands for the statements (i) to (iv) and give outputs for SQL queries (v) to (viii).

6

TABLE : CONSIGNOR

CnorID	CnorName	CnorAddress	City
ND01	R Singhal	24, ABC Enclave	New Delhi
ND02	Amit Kumar	123, Palm Avenue	New Delhi
MU15	R Kohli	5/A, South Street	Mumbai
MU50	S Kaur	27-K, Westend	Mumbai

TABLE : CONSIGNEE

CneeID	CnorID	CneeName	CneeAddress	CneeCity
MU05	ND01	Rahul Kishore	5, Park Avenue	Mumbai
ND08	ND02	P Dhingra	16/J, Moore Enclave	New Delhi
KO19	MU15	A P Roy	2A, Central Avenue	Kolkata
MU32	ND02	S Mittal	P 245, AB Colony	Mumbai
ND48	MU50	B P Jain	13, Block D, A Vihar	New Delhi

- (i) To display the names of all Consignors from Mumbai.'
- (ii) To display the CneeID, CnorName, CnorAddress, CneeName, CneeAddress for every Consignee.
- (iii) To display consignee details in ascending order of CneeName.
- (iv) To display number of consignors from each city,
- (v) `SELECT DISTINCT City FROM CONSIGNEE;`
- (vi) `SELECT A.CnorName, B.CneeName
FROM Consignor A, Consignee B
WHERE A.CnorID = B.CnorID AND B.CneeCity = 'Mumbai';`
- (vii) `SELECT CneeName, CneeAddress
FROM Consignee
WHERE CneeCity NOT IN ('Mumbai', 'Kolkata');`
- (viii) `SELECT CneeID, CneeName
FROM Consignee
WHERE CnorID='MU15' OR CnorID='ND01';`

6. (a) State De Morgan's Theorems and verify the same using truth table. 2

(b) Write the equivalent Canonical Product of Sum Expression for the following Sum of Product Expression

$$F(X, Y, Z) = \Sigma (0, 2, 4, 5) \quad 2$$

(c) Write the equivalent Boolean expression for the following Logic Circuit. 2

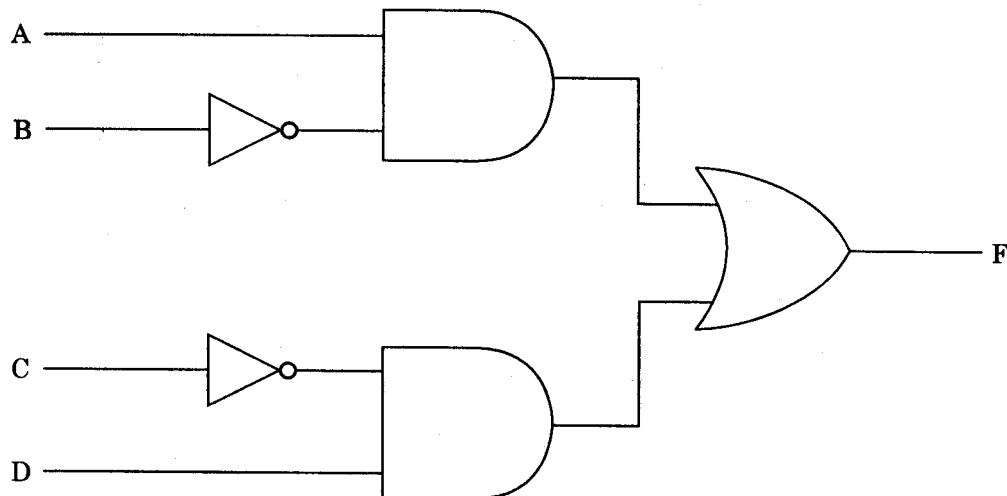

(d) Reduce the following Boolean expression using K-Map : 2

$$F(A, B, C, D) = \pi(5,6,7,8,9,12,13,14,15)$$

7. (a) What is the significance of Cyber Law ? 1

(b) Expand the following terms with respect to Networking : 2

(i) XML

(ii) WWW

(iii) WLL

(iv) TCP/IP

(c) Which of the following units measures the speed with which data can be transmitted from one node to another node of a network ? Also, give the expansion of the suggested unit. 1

(i) KMph

(ii) Mbps

(iii) MGps

- (d) “Hindustan Connecting World Association” is planning to start their offices in four major cities in India to provide regional IT infrastructure support in the field of Education & Culture. The company has planned to set up their head office in New Delhi in three locations and have named their New Delhi offices as “Sales Office”, ”Head Office” and “Tech Office”. The company’s regional offices are located at ”Coimbatore”, “Kolkata” and “Ahmedabad”.

A rough layout of the same is as follows :

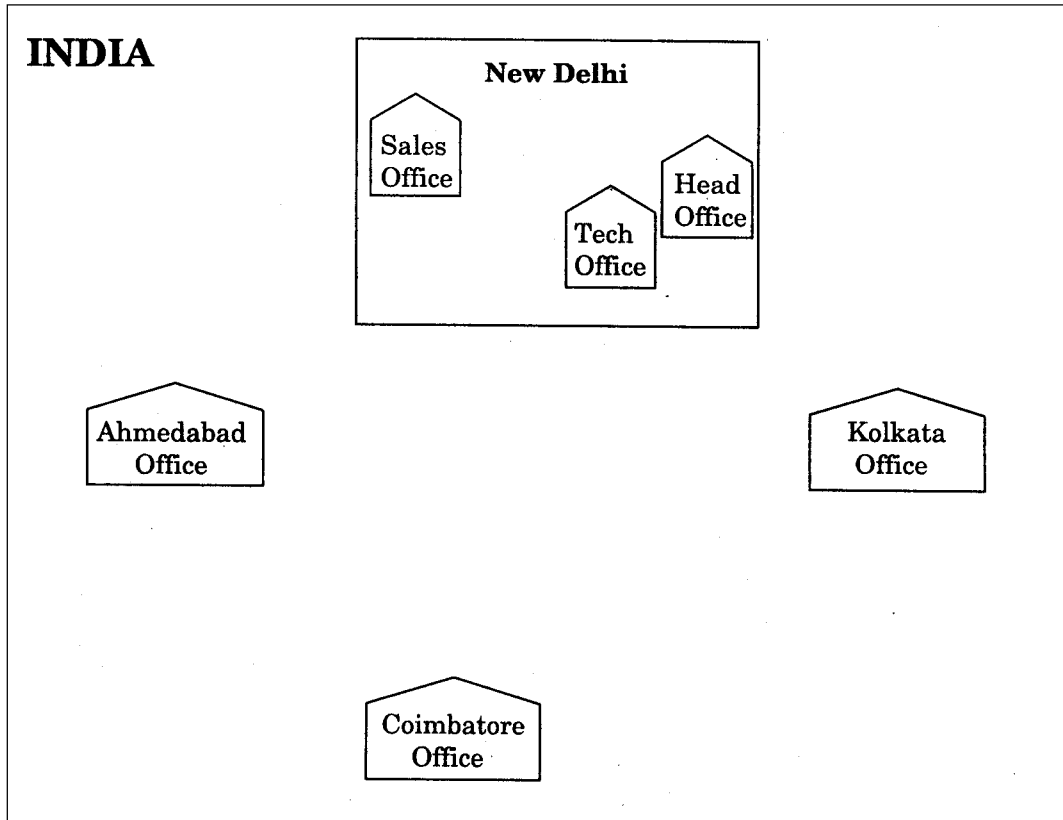

Approximate distances between these offices as per network survey team is as follows:

Place From	Place To	Distance
Head Office	Sales Office	10 KM
Head Office	Tech Office	70 Meter
Head Office	Kolkata Office	1291 KM
Head Office	Ahmedabad Office	790 KM
Head Office	Coimbatore Office	1952 KM

In continuation of the above, the company experts have planned to install the following number of computers in each of their offices :

Head Office	100
Sales Office	20
Tech Office	50
Kolkata Office	50
Ahmedabad Office	50
Coimbatore Office	50

- (i) Suggest network type (out of LAN, MAN, WAN) for connecting each of the following set of their offices :
 - Head Office and Tech Office
 - Head Office and Coimbatore Office
- (ii) Which device will you suggest to be procured by the company for connecting all the computers within each of, their offices out of the following devices ?
 - Modem
 - Telephone
 - Switch/Hub
- (iii) Which of the following communication media, will you suggest to be procured by the company for connecting their local offices in New Delhi for very effective and fast communication ?
 - Ethernet Cable
 - Optical Fiber
 - Telephone Cable
- (iv) Suggest a cable/wiring layout for connecting the company's local offices located in New Delhi. Also,, suggest an effective method/technology for connecting the company's regional offices at "Kolkata", "Coimbatore" and "Ahmedabad".

4