

# Electronics-Engineering

## PRACTICE SET-3

1. Assertion (A) : The poles of the driving point immittance function of an RLC network  
have negative real parts.  
Reason (R) : The network is made up of Passive elements.
2. The characteristic impedance of a lossless transmission line is given by
  - A.
  - B.
  - C.  $1 /$
  - D.
3. MOS controlled thyristors have
  1. Low forward voltage drop during conduction
  2. Fast turn-on and turn-off time
  3. Low switching losses
  4. High reverse voltage blocking capability
  5. Low gate input impedance
  - A. 1, 2 and 3 are correct
  - B. 3, 4 and 5 are correct
  - C. 2, 3 and 4 are correct
  - D. 1, 3 and 5 are correct
4. The moving coil in a dynamometer wattmeter is connected
  - A. in series with the fixed coil
  - B. across the supply
  - C. in series with the load
  - D. across the load.
5. In a linear system, an input of  $5 \sin \omega t$  produces in output of  $10 \cos \omega t$ . The output corresponding to input  $10 \cos \omega t$  will be equal to
  - A.  $+5 \sin \omega t$
  - B.  $-5 \sin \omega t$
  - C.  $+20 \sin \omega t$
  - D.  $-20 \sin \omega t$
6. Choose the correct statement (s) from the following
  - A. PROM contains a programmable AND array and a fixed OR array.
  - B. PLA contains a fixed AND array and a programmable OR array.
  - C. PROM contains a fixed AND array and programmable OR array
  - D. None of the above.

7. With reference to the GC circuit shown in figure below, the input resistance looking into the base is

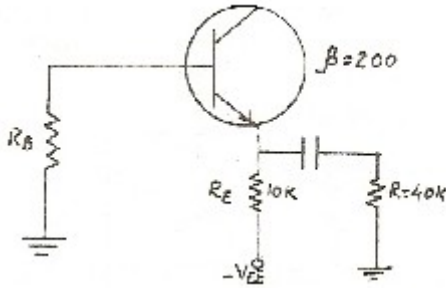

- A. 8 M  
B. 200 ohm  
C. 1.6 M  
D. 2 M.
8. UHF band is given by  
A. 3 MHz to 30 MHz  
B. 30 MHz to 300 MHz  
C. 300 MHz to 300 MHz  
D. 300 KHz to 30 MHz
9. An 'Assembler' for a microprocessor is used for  
A. assembly of processors in a production line  
B. creation of new programmes using different modules  
C. translation of a program from assembly language to machine language  
D. translation of a higher level language into English text
10. Raman spectroscopy may often be used to  
A. examine vibrations of molecules in the infrared region  
B. identify compounds, especially in the ultraviolet  
C. identify the structural type of the compounds under study  
D. identifies compounds, but only at conditions of low temperatures and high pressures.
11. The Miller indices of the diagonal plane of a cube are  
A. 110  
B. 111  
C. 100  
D. 000
12. The colour TV system adopted in India is  
A. PAL system  
B. NTSC system  
C. CCTV system  
D. none of the above

13. After a target has been acquired by a Radar, the best scanning system for tracking is
- conical
  - spiral
  - helical
  - none of these
14. In a multicavity magnetron, strapping is employed primarily
- to prevent mode jumping
  - to increase the separation between the resonant frequencies in the mode and in the Adjacent modes
  - to reduce the back heating of the cathode
  - to increase the output of the magnetism
15. The distance of a geostationary satellite from the surface of the earth is nearly
- 360 km
  - 3600 km
  - 36,000 km
  - 360,000 km.

16. A step input as shown in Fig. -II is given to the circuit shown in Fig. -I. The output is as shown in Fig. -III. The rise time of the circuit response is equal to

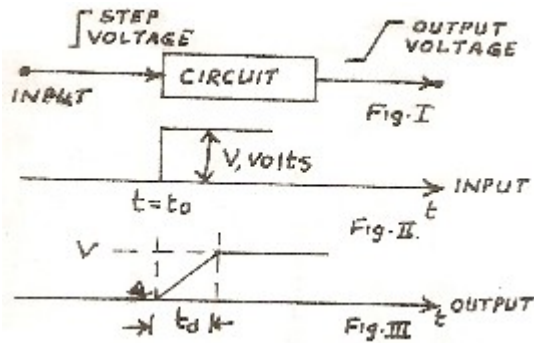

- $t_d$
  - The time taken to reach 100% of  $V$  from the instant at which the output is 5% of  $V$ .
  - The time taken to reach 95% of  $V$  from A
  - The time taken to reach 90% of  $V$  from the instant at which the output is 10% of  $V$ .
17. The noise temperature of sky is about
- $100^\circ \text{K}$
  - $273^\circ \text{K}$
  - $0^\circ \text{K}$
  - $30^\circ \text{K}$
18. for a sinusoidal input voltage

$$V_s = V_m \sin wt =$$

If the input voltage is connected to load for  $n$  cycles and is disconnected for  $m$  cycles, the rms output voltage is given by

$$V_0 = V_s$$

Where duty cycle  $K$  is given by

- A.  $m + n$
  - B.  $m - n$
  - C.  $mn$
  - D.  $n / (m + n)$
19. For a given frequency, the deflecting torque of an induction ammeter is directly proportional to
- A. current<sup>2</sup>
  - B. current<sup>3</sup>
  - C. current
  - D. current
20. As compared to a closed loop system an open loop system is
- A. more stable as well as more accurate
  - B. less stable as well as less accurate
  - C. more stable but less accurate
  - D. less stable but more accurate
21. Figure shown below the circuit of a gate in the Resistor Transistor Logic (RTL) family. The circuit represents a

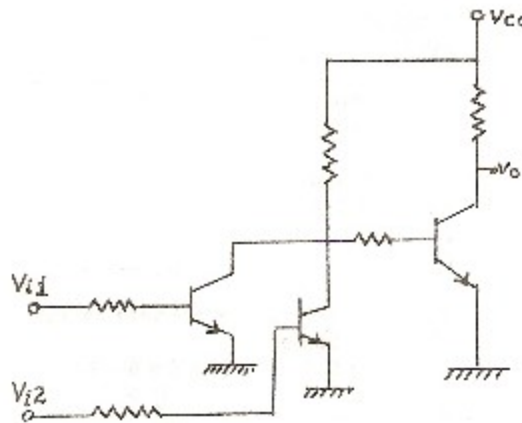

- A. NAND
  - B. AND
  - C. NOR
  - D. OR
22. The value of  $I_{CBO}$  in a silicon transistor of  $\beta = 49$  is 20 nA. The value of  $I_{CEO}$  for a temperature rise of 18 °C would be
- A. 8  $\mu$ A
  - B. 160 nA

- C. 1 -A  
D. 7.84 A
23. The skip distance does not depend upon  
A. frequency of the signal transmitted  
B. angle of beaming of the wave  
C. type of wave propagation  
D. the power transmitted.
24. In an 8085 -P system, the RST instruction will cause an interrupt  
A. only if an interrupt service routine is not being executed  
B. only if a bit in the interrupt mask is made 0  
C. only if interrupts have been enabled by an EI instruction  
D. none of the above
25. Match the following
- | Column - I                                 | Column - II      |
|--|------------------|
| A. Donor impurity element for Germanium    | (i) Boron        |
| B. Donor impurity element for Silicon      | (ii) Indium      |
| C. Acceptor impurity element for Germanium | (iii) Arsenic    |
| D. Acceptor impurity element               | (iv) Phosphorous |
| A. A-(i), B-(ii), C-(iii), D-(iv)          |                  |
| B. A-(iv), B-(iii), C-(ii), D-(i)          |                  |
| C. A-(ii), B-(iii), C-(iv), D-(i)          |                  |
| D. A-(iii), B-(iv), C-(ii), D-(i)          |                  |
26. The electronic configuration of an iron atom is  
A.  $1s^2 2s^2 2p^6 3s^2 3p^6 3d^6 4s^2$   
B.  $1s^2 2s^2 2p^6 3s^2 3p^6 3d^3 4s^2$   
C.  $1s^2 2s^2 2p^6 3s^2 3p^6 3d^8 4s^2$   
D. None of the above.
27. In TV picture tube, the electron beam is deflected  
A. equalizing pulses  
B. magneto statically  
C. both electro statically and magneto statically  
D. none of the above
28. Most of the aircraft surveillance Radars operated in  
A. X band  
B. C band  
C. L band  
D. S band
29. Wave guides of convenient dimensions are employed in the range of  
A. 500 MHz - 1 G Hz

- B. 3 - 100 GHz  
 C. 50 - 5000 GHz  
 D. None of the above.
30. For satellite communication, the frequency should be  
 A. less than the critical frequency of ionosphere  
 B. equal to the critical frequency of ionosphere  
 C. more than the critical frequency of ionosphere  
 D. none of the above
31. A balanced star-connected load with impedance of  $20 \angle 30^\circ$  ohm is supplied from a 3-phase, 4-wire, 173 volt system, the voltages to neutral being  $100 \angle 90^\circ$ ,  $100 \angle 0^\circ$  and  $100 \angle 150^\circ$  V. The current in the neutral wire is  
 A. 5 A  
 B. 8.85 A  
 C. zero  
 D. 50 A
32. The average noise temperature of earth, as viewed from space, is  
 A.  $254^\circ$  K  
 B.  $303^\circ$  K  
 C.  $100^\circ$  K  
 D.  $500^\circ$  K
33. A SCHOTTKY diode is a  
 A. majority device  
 B. minority carrier device  
 C. fast recovery diode  
 D. both a majority and a minority carrier diode
34. The scale of a voltmeter is uniform. Its type is  
 A. moving iron  
 B. induction  
 C. moving coil permanent magnet  
 D. moving coil dynamometer
35. Consider the following statements regarding time-domain analysis of a control system:  
 1. Derivative control improves system's transient performance  
 2. Integral control does not improve system's steady state performance  
 3. Integral control can convert a second order system into a third order system.  
 Of these statements:  
 A. 1 and 2 are correct  
 B. 1 and 3 are correct

- C. 2 and 3 are correct
- D. 1, 2 and 3 are correct.

36. The initial contents of the 4-bit serial-in-parallel-out, right-shift, Shift Register shown in figure below, is 0110. After three clock pulses are applied, the contents of the Shift Register will be

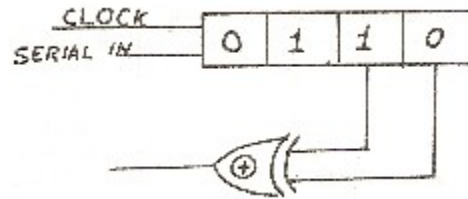

- A. 0000
- B. 0101
- C. 1010
- D. 1111

37. In figure below, the value of  $R_E$  which will saturate the transistor is very nearly

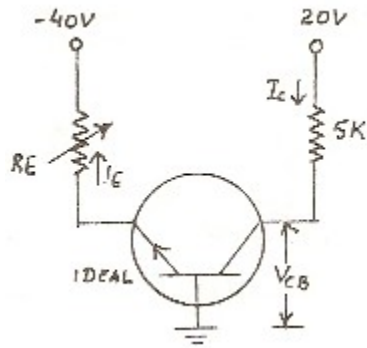

- A. 5 K
- B. 10 K
- C. 20 K
- D. 25 K

38. A Yagi-uda array does not have

- A. high gain
- B. high band - width
- C. parasitic reflector
- D. parasitic director

39. An I / O processor control the flow of information between

- A. cache memory and I / O devices
- B. main memory and I / O devices
- C. Two I / O devices
- D. cache and main memories

40. Match the following:

Column - I

Column - II

- |        |       |         |
|--------|-------|---------|
| A. EHF | (i)   | 100 KHz |
| B. HF  | (ii)  | 10 MHz  |
| C. LF  | (iii) | 10 GHz  |
| D. SHF | (iv)  | 100 GHz |

- A. A-(i), B-(ii), C-(iii), D-(iv)  
 B. A-(iv), B-(iii), C-(i), D-(iii)  
 C. A-(iii), B-(ii), C-(i), D-(iv)  
 D. A-(ii), B-(i), C-(iii), D-(iv)

41. Semiconductors have electrical conductivities 0 the following order ( $\text{ohm-cm}^{-1}$ )  
 A.  $10^{-15}$   
 B.  $10^{-3}$   
 C.  $10^4$   
 D.  $10^{10}$
42. Which of the following pulses have the largest width?  
 A. equalizing pulses  
 B. vertical pulses  
 C. horizontal pulses  
 D. none of the above
43. If the peak transmitted in a Radar system is increased by a factor of 81, the maximum range increases by a factor of  
 A. 81  
 B. 9  
 C. 3  
 D. 6
44. Propagation frequencies in UHF range takes place by means of  
 A. surface waves  
 B. space waves  
 C. ground waves  
 D. sky waves
45. A passive satellite  
 A. only reflects back signals  
 B. only generates signals  
 C. only absorbs signals  
 D. Receivers, modulates and then reflects.
46. The transformed current in a certain branch of a circuit is  $(2s + 5) / (s + 3)$ . The value of the current for  $t = 0$  \_ is  
 A. 0  
 B. 2



- C. 3  
D. 5
47. Which of the following relations is correct?  
 A.  $\frac{d}{dt}(AB) = \frac{dA}{dt} \times B - A \cdot \frac{dB}{dt}$   
 B.  $\frac{d}{dt}(AB) = \frac{dA}{dt} \cdot B + A \cdot \frac{dB}{dt}$   
 C.  $\frac{d}{dt}(AB) = A \cdot \frac{dB}{dt} + B \cdot \frac{dA}{dt}$   
 D. All the three.
48. A thyristorised, three phase, fully controlled converter feeds a dc load that draws a constant current. Then the input ac line current to the converter has  
 A. an rms value equal to the dc load current  
 B. an average value equal to the dc load current  
 C. a peak value equal to the dc load current  
 D. a fundamental frequency component, whose rms value is equal to the dc load current
49. The power in a resistor R is estimated by measuring the voltage and current using the voltmeter-ammeter method. Two different arrangements can be used as shown in circuits I and II. Less erroneous results are obtained by adopting

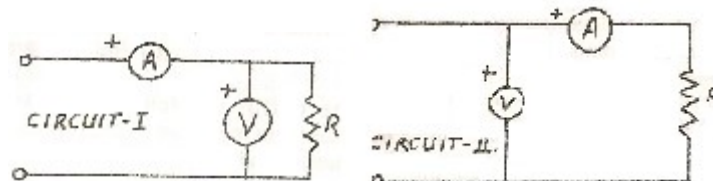

- A. circuit 1 for low values of R  
 B. circuit II for low values of R  
 C. circuit I for high values of R  
 D. Circuit II for low and high values of R.
50. The open loop transfer function of a unity negative feedback control system is given by  

$$G(s) = K(s + 2) / (s + 1)(s - 7).$$
 For  $K > 6$ , the stability characteristics of the open loop and closed loop configurations of the system are respectively  
 A. stable and stable  
 B. unstable and stable  
 C. stable and unstable  
 D. Unstable and unstable.

## Solution

- 1.(B). Both A and R are true but R is not a correct explanation of A.  
 2.(B). The characteristic impedance of a lossless transmission line is given by

- 3.(A). MCT have low reverse voltage blocking capability and high gate input impedance.
- 4.(D). The moving coil in a dynamometer wattmeter is connected across the load.
- 5.9D).  $\sin wt * 2 \cos wt$   
 Differentiating  
 $\cos wt * -2 \sin wt$   
 Therefore, an input of  $10 \cos wt$   
 Will cause a response of  $-20 \sin wt$
- 6.(C). PROM contains a fixed AND array and a programmable OR array is the correct statement.
- 7.(C).  $r_{in} = xR_E \parallel R = 200 \times (40 \times 10 / 50) = 1.6M$
- 8.(C). VHF - 30 to 300 MHz, UHF = 0.3 to 3 GHz.
- 9.(C). An 'Assembler' is used for translation of a program from assembly language to machine language.
- 10.(A). Some (symmetrical) molecules such as ethylene ( $CH_2 = CH_2$ ) do not exhibit all their vibrations in infrared spectra. Raman spectroscopy helps, by examining the vibrations of these molecules.
- 11.(A0). The Millar indices of the diagonal plane of a cube are 110.
- 12.(A). PAL system
- 13.(A). Conical is the best system for tracking.
- 14.(A). In a multicavity magnetron, strapping is employed primarily to prevent mode jumping.
- 15.(C). It is nearly 36,000 km.
- 16.D. By definition the correct answer is at (d).
- 17.D. The noise temperature of sky is about  $30^\circ K$ .
- 18.D.  $K = n / (m + n)$
- 19.A. For a given frequency, the deflecting torque of an induction ammeter is directly proportional to current<sup>2</sup>.
- 20.C. There is no question of instability of open loop-systems. But it is not capable of maintaining the output at the desired value or prefixed value.
- 21.D.

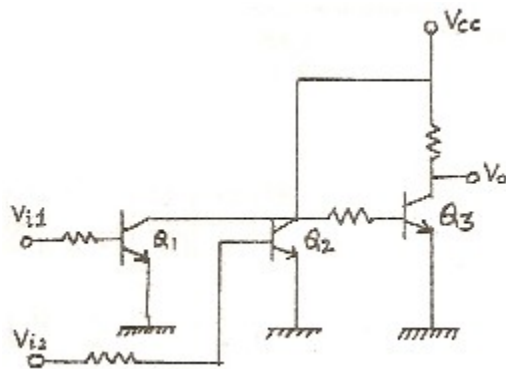

$Q_1$  and  $Q_2$  from a direct coupled transistor logic (DCTL) giving NOR output

$V_{11}$	$V_{12}$	O/P $Q_1$	O / P $Q_2$	Logic
L(0)	L(0)	H (1)	H (1)	1
L (0)	H(1)	L (0)	L (0)	0
H (1)	L(0)	L (0)	L (0)	0
H (1)	H(1)	L (0)	L (0)	0

Logic NOR

$Q_3$  is an inverter.

$$\text{⊗ } V_0 = \text{OR}$$

22.A. Value of  $I_{CEO}$  after temperature rise of 18 °C is

$$= (\beta + 1) \times \text{new value of } I_{CBO}$$

$$= (40 + 1) \times 2^3 \times 20 \text{ nA} = 8 \text{ uA}$$

In general,  $I_{CEO} = (\beta + 1) I_{CBO}$

23.C. The distance between the transmitting antenna and the point where the sky wave is first received after returning to earth is called the skip distance. It depends upon the frequency of the signal transmitted, angle of beaming of the wave and the power transmitted.

24.C. The RST instruction will cause an interrupt only if interrupts have been enabled by an EI instruction.

25.D. Donor impurity elements give electrons to form N - type semi-conductor. Arsenic and Antimony are used for Germanium and phosphorous for Silicon.

Acceptor impurity elements take electrons to form P - type semiconductor.

Gallium and Indium for Germanium and Aluminum and Boron for Silicon

26.A. The electronic configuration of an iron atom is

$$1s^2 2s^2 2p^6 3s^2 3p^6 3d^6 4s^2$$

27.B. In TV picture tube, the electron beam is magnetically static.

28.C. L band is operated in most of the aircraft surveillance radars.

29.A. Waveguides are not used for frequencies below 1 GHz.

30.C. For satellite communication, the frequency should be more than the critical frequency of ionosphere.

31.C. Since the applied 3-phase voltage is balanced and the impedances are all equal, the currents also would be balanced, as a result there is no current in the neutral wire.

32.A. The average temperature of earth, as viewed from space, is 254° K.

33.A. Although a Schottky diode behaves as a pn-junction diode, there is no physical junction; and as a result a Schottky diode is a majority carrier diode.

34.C. The scale of a voltmeter is uniform. Its type is moving coil permanent magnet.

35.B. For same kV, the natural frequency  $\omega_n$  remains unchanged in derivative control while damping is increased by  $(K_D / 2)$ : Thus it improves the transient response.

Integral compensator introduces a term like  $K$  ( $K$  is const.), thus changes second order to third, therefore the answer is (b).

36.C. Clock State Remarks  
Pulse \_\_\_\_\_

37.B. For saturation  $V_{CB} = 0$ .  $I_C = 20/5 = 4$  mA.  
 Also,  $I_E = I_C = 4$  mA. Now,  $I_E R_E = 40$  V.  
 Hence,  $R_E = 40/4 = 10$  K.

38.A. A Yagi-uda array does not have high gain.

39.B. Main memory and I / O devices

40.B. Frequency	Range
EHF	10 GHz to 300 GHz
HF	3 MHz to 30 MHz
LF	30 kHz to 300 kHz
SHF	3 GHz to 30 GHz

41.B. Semiconductors have electrical conductivities of the order of  $10^{-3}$

42.B. Vertical pulses have the largest width.

43.C. It will increase by a factor of three.

44.B. Space waves.

45.A. A passive satellite only reflects back signals.

46.B.

Dividing numerator and denominator by  $s^2$ ,

47.D.

48.C.

49.A. It is an elementary piece of knowledge. For low resistance measurements, if circuit II is used, the ammeter resistance which may be comparable with the low resistance being measured gets added to the unknown and thereby causing larger error.

50. B.

Since there is a pole in RHP of complex s-plane, the open loop system is unstable.

$$k(s + 2) + (s + 1)(s - 7) = 0$$

$$\text{or } s^2 + s(k - 6) + (2k - 7) = 0$$

$s^2$       1      (2k - 7)      It is seen that for  $k > 6$  the first column of the

$$\begin{array}{l} s^1 \quad (k-7) \quad 0 \\ s^0 \quad (2k-7) \quad 0 \end{array}$$

Routh table has all entries of the same sign; hence the system is stable